

**Welcome!**

**You have found the 1949-59 Ford Mercury Association web page. You can purchase parts using the page or call 614 905 2151 and talk to John Tim Halter who has over 50 years experience. If I do not answer your call, please leave a voice mail and I will get back with you.**

## **Business matters.**

**I have been selling on eBay for over 12 years and always price what I sell at what I know is a fair price. I pride myself in doing that. But things change. eBay has raised it's selling fee to over 12% This means if you buy from us using eBay your cost will be at least 12% more than buyoing direct from us. Call us, we take all credit cards. 614 905 2151**

**We have added many new items and by browsing our web site you can find them here. Rear Convertible top window frame, Fan shroud and many other items.**

**Enjoy our web site, we publish a news letter every couple of months that cost you \$35.00 per year. You can advertise free. We manufacture a lot of our parts, like all the castings for the 49-53 Ford Convertibles. We make a fan shroud also. Enjoy the web site, and any questions call me 614 905 2151 or email [association.fordmerc@gmail.com](mailto:association.fordmerc@gmail.com)**

**Thank you for your business**

**John Tim and Barbara Halter**

**1949-51 Ford Convertible top parts. All parts shown are either NOS, or used and quantities are limited.**

*Some parts were removed from junk convertibles, condition represents that. All are in good useable condition.*

**Please see the top drawing for reference. Use your**

**Credit card to purchase by calling Barbara 740-503-**

**5050. All prices plus freight. Rear 1949 50 Ford Convertible frame is in stock now. 9" x 26" \$525.00+ S&H**

**Look at all pages for NEW Top parts that we are manufacturing! The Dowels Top header pins and the Handel that locks down the top. Also we are making a fan shroud.**



#50330 Buckle connector, available in passenger and drivers side. \$25.00 each



# 50308 Connects rail 3 to rail 2. Available in Drivers & Passenger. \$20.00 each



#50454 Connector/Adjustment rod connects between rail one and two. Available in passenger and drivers side. This is the rod you use to correct the sag on the sides. Order drivers or passenger side. \$25.00 each

**We have different rods available call for pricing**

We have the rear window crank handles available used with and without the round ball. Call for availability, as this changes from day to day.

Tim 614 905 2151 **We take all credit cards**



Convertible top stainless steel to tuck in the top behind rear side window \$75.00 only one small left And 2 regular size \$175.00 set

1951 Mercury Front fender stainless, NOS has no dings or scrapes, but needs cleaning. A good buffing will do wonders. Been on a parts shelf since 1951. Very rare and almost impossible to find. Set only \$274.00

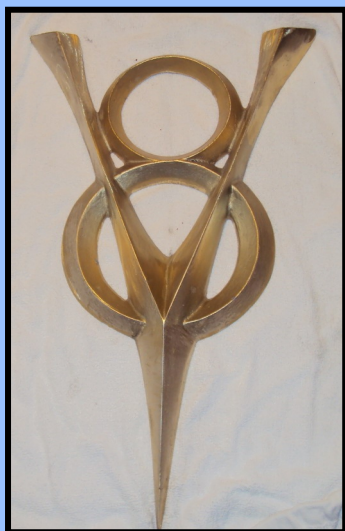

Solid Brass V8 A spectacular edition to any collection. \$249.95 plus shipping. **Aluminum \$ 60.00**



1949 Mercury driver side fender stainless, very hard to find, and rare. This is a NOS piece and has been on a parts shelf since 1949 I would guess. Needs some buffing to look like new, no dings or scratches. I do not have the passenger side. **\$149.00**



**Aluminum V8 16" X 21" + -  
A great wall hanging.**

**\$60.00 + shipping.**

**Order yours today!**



As-  
sorted  
1949-  
50-51  
Ford /  
Mer-  
cury  
Mon-

&

arch Parts, some NOS but show some shelf rubs and some used. We have taken photos as best we can showing the part along with any scuff marks, surface rust, dents and so on. All parts are sold as is. NO guarantees or warranty expressed or given. Any questions call Tim at 614-905-2151 or Email at [association.fordmerc@gmail.com](mailto:association.fordmerc@gmail.com)

**All prices plus shipping. We take Pay Pal or call for credit card.**

1942-48 Mercury fender moldings, left and right. Limited quantity. Excellent condition, NOS most still in factory wrapper FM-164-R-8-M 16003 16004 Also used on Mercury Station Wagons I have been told and Canadian Monarch. Almost impossible to find. A set was on Ebay for \$375.00 and sold.

**\$249.95 pair**

**We have in stock from time to time 1949-53 Ford Convertible top parts besides the castings that we manufacture. We have side rails both drivers side and passenger sides,**

**This inventory changes from day to day as we are always buying and selling these parts. We may not have them in stock today but may have them in a week.**

**All of these parts are used and in different conditions. Many need sand blasting or just a minor clean up. Call 614 905 2151 for availability.**



**Fan Shroud for 1949 50 51 52 53 Ford Cars. This is manufactured by us. They fit and come painted black. Shipping via USPS. Extra \$249.00**

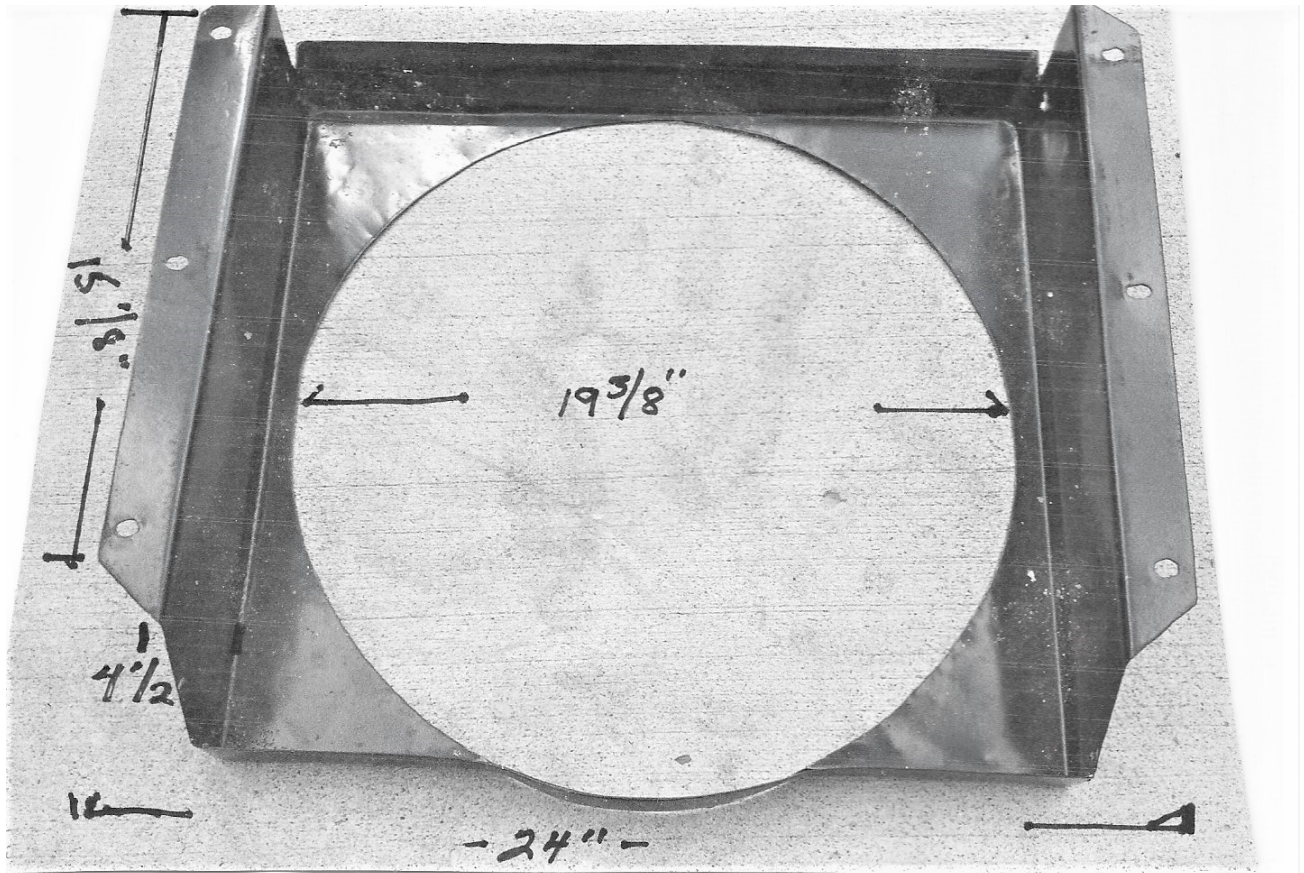

**1950 Ford Convertible rear seat riser. Made from 316 Stainless steel. \$50.00 plus USPS.**

Part # S # OA7660653 NEW Stainless Steel Molding Rear Seat Riser . 1950 Ford Convertible. \$50.00each.  
Very limited quantity



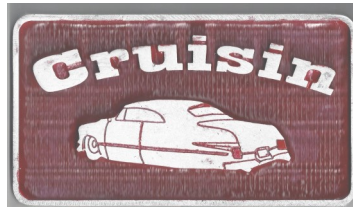

We have many more tail dragging plaques available and we are adding new plaques monthly. Prices start at \$25.00 + Shipping 9.75

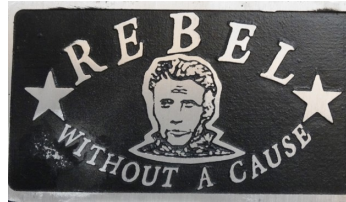
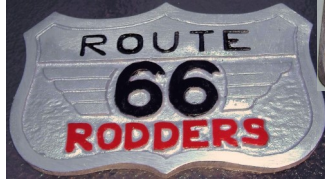

The 1949-53 Ford Mercury Association makes all the castings and bolts for 1949-50 tops.

To order call 740-503-5050 or 614-905-2151. You can use your Credit card.

If you need individual top irons and parts call for your request.



Stainless steel license plate bracket, exact duplicate of the OEM part by FORD. Paint it black if you want a NOS look. Polish to make it look cool \$25.00 ea. Limited supplies



We have a large selection of car plaques and are adding more every month. 8.5" x 5.5"

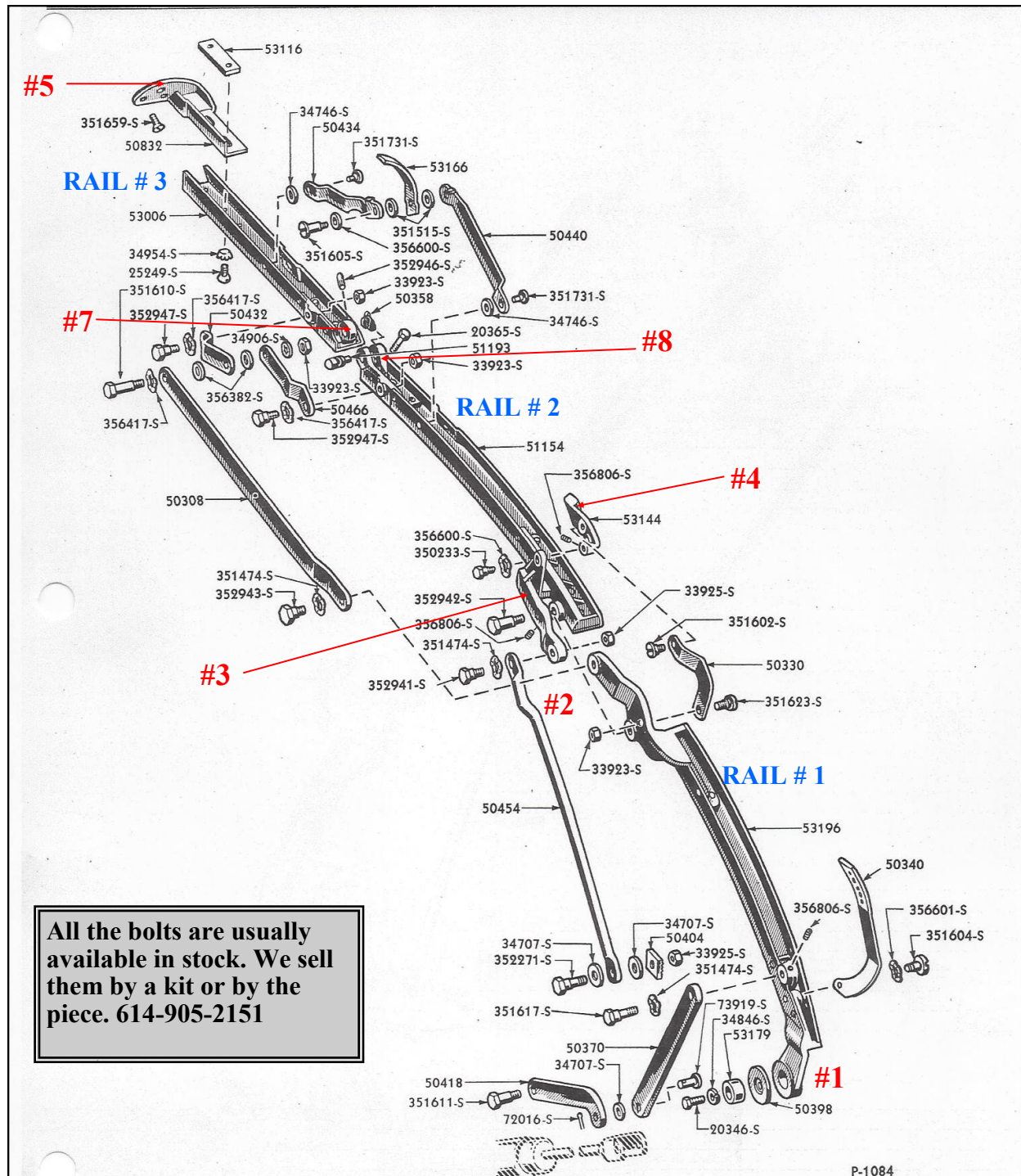

All the bolts are usually available in stock. We sell them by a kit or by the piece. 614-905-2151

The 1949-50 Ford Convertible tops are the same with the exception for some shoulder bolts. All castings are the same and the 1949-59 Ford Mercury Association manufactures them all in Columbus Ohio. All castings are ready to install. *No machining needed.* All parts available listed and castings are either for Drivers or Passenger side.



We have a used top windshield bow in stock

1951 Ford Convertible top drawing

We manufacture this part #03570

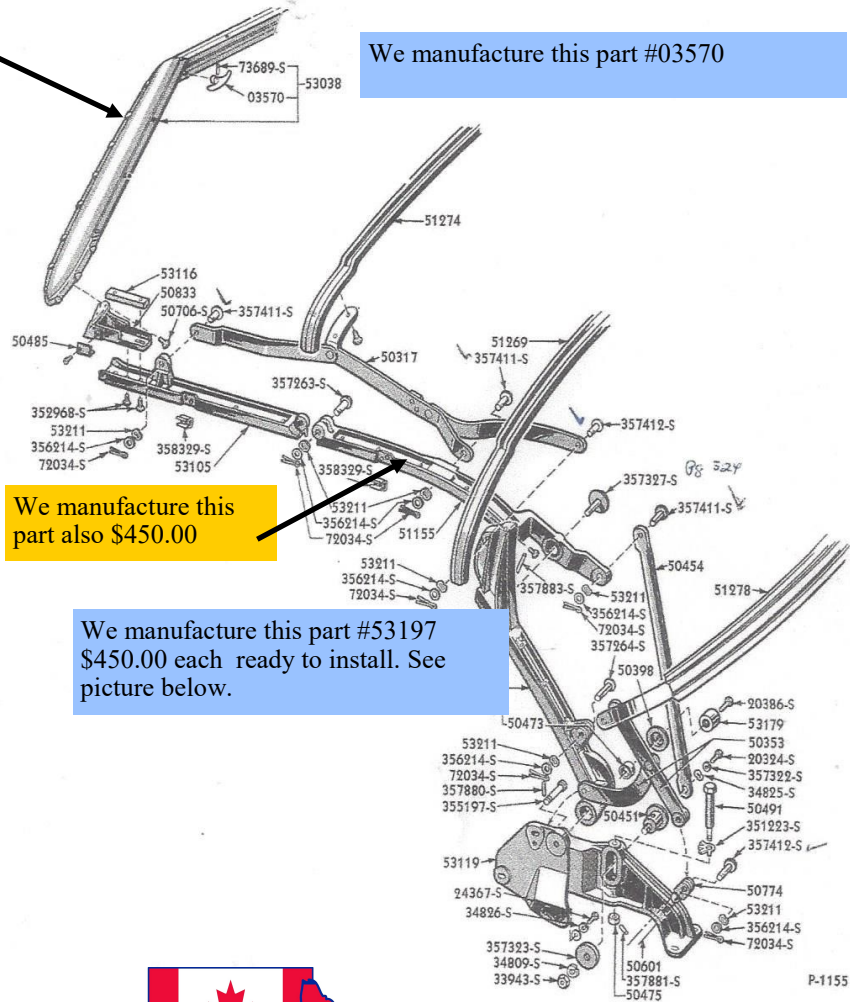

We manufacture this part also \$450.00

We manufacture this part #53197 \$450.00 each ready to install. See picture below.



This SAND casting is made from original molds, We guarantee it to fit. No returns without prior authorization. No return if altered in any way. Subject to a restocking fee.

Made in USA, Columbus Ohio from Air Craft 303 Aluminum.





**New Item for 2022**

We are now making out of Solid Bronze just like Henry did the Convertible top handle that turns to lock down the header bow. We offer them In Chrome **\$199.00** and plane Bronze ready for plating. **\$99.00 + Shipping**



We are making out of Solid Bronze the three pin set available in Chrome. Or plane Bronze so you can plate them. Due to the fluctuations in the price of Chrome & Bronze, we cannot price them here.

**Call for pricing 614-905-2151**

**Subscribe today to our Newsletter.**



We are also making the plates that screw onto the header bow that are used to dress up the holes. We are making them from Aluminum. The original ones were Bronze. 25.00 each



Revised 3/22

**If you own a 1949 or 1950 Ford Convertible and want to install a overdrive transmission you need this Overdrive adapter.**

**\$275.00**

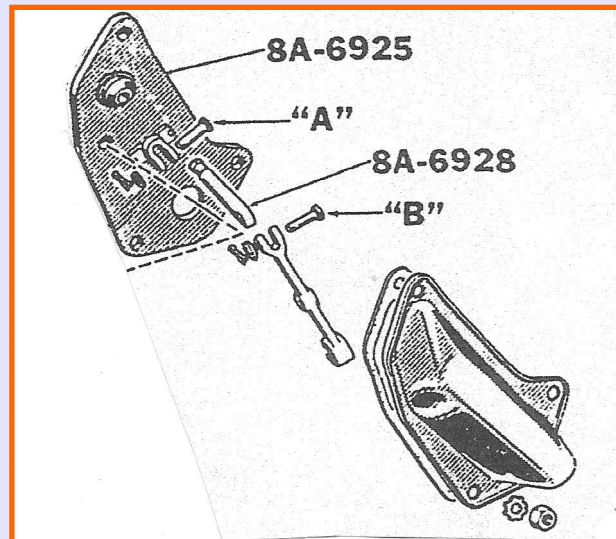

**We manufacture this using 303 Aluminum for the cover and D2 steel for the base. All other parts are made by us also. It comes ready to install. Does not come with gasket.**

**What this adapter does is offset the solenoid so it does not hit the X frame.**

**You must have the transmission, as the 49 & 50 have the governor on it and the 51 does not use a governor. This only works on the 49 & 50. Also you will need the cable, electrical harness and the solenoid & relay. For more information, call us 614-905-2151 Tim**



**JOIN TODAY** the Greatest News-letter around! 614 905 2151

**Rear window frame for 1949 1950 Ford Convertibles. 9" x 26" Chrome plated inside and out and comes with a plexiglass "window" that can be used as is, or as a pattern for a glass window. We do not supply the glass.**



**We make them in 4" X 20" , 5 1/2" x 24" , 7" X 21" 9" x 26" Call for pricing 614 905 2151**

**Revised 3/1/2022**